



# Compressed Air Dryer and Filtration Unit

## User Manual

[www.keit.co.uk](http://www.keit.co.uk)

[support@keit.co.uk](mailto:support@keit.co.uk)

## Table of Contents

1. Introduction.....	3
1.1. How it works .....	3
1.2. Components – External .....	4
1.3. DFU02 Components – Internal .....	6
2. Using the dryer .....	7
2.1. Starting the unit .....	7
2.2. During regular use .....	8
2.3. Stopping the unit.....	8
2.4. Long-term storage .....	8
3. Maintenance .....	9
3.1. Maintenance schedule.....	10
3.2. Maintenance alarms .....	11
4. Dryer Maintenance.....	12
4.1. SMC AFD30 Filter Replacement.....	12
4.2. SMC AW30 Filter Replacement .....	14
4.3. UD7+ Filter Replacement .....	16
4.4. QD7+ Filter Replacement .....	18
4.5. Exhaust Silencers Replacement .....	20
4.6. CD1.5+ Desiccant Cartridge Replacement .....	21
4.7. CD1.5+ Solenoid Valve Replacement .....	24
5. Technical Specifications.....	26
6. List of Parts.....	27
7. Warranty .....	28
8. Appendix 1 – Electronics Enclosure detail view .....	29
9. Appendix 2 – Circuit Diagram for 240V Version .....	30
10. Appendix 3 – Circuit Diagram for 110V Version .....	31
11. Appendix 4 – Purge setup for multiple Instruments .....	32
12. Appendix 5 – DFU01 dryer internal components.....	34
13. Appendix 6 – DFU01 dryer Maintenance schedule .....	35

## 1. INTRODUCTION

The Air Dryer and Filtration unit delivers dry, clean compressed air at a controlled flow rate and pressure. It operates using an external compressed air source. Currently, two variants are in use: the DFU01 and DFU02 dryers.

The model variant is indicated inside the unit, on the back of the front door panel:



### 1.1. How it works

Both DFU01 and DFU02 are twin-tower, heatless regenerative desiccant dryers. Moist air passes over a hygroscopic material (such as silica gel, molecular sieves, or activated alumina), which adsorbs water vapor and dries the air. As the desiccant becomes saturated, it is regenerated in the second tower, allowing continuous operation.

These dryers typically achieve a dew point of  $-70^{\circ}\text{C}$ , making them suitable for critical applications. Pre-filters protect the desiccant from contaminants, preserving efficiency and service life.

The unit supports single or multiple instrument installations. For multiple instruments, ensure proper purge rates for all devices (see Appendix 4 for a system diagram).

## 1.2. Components – External

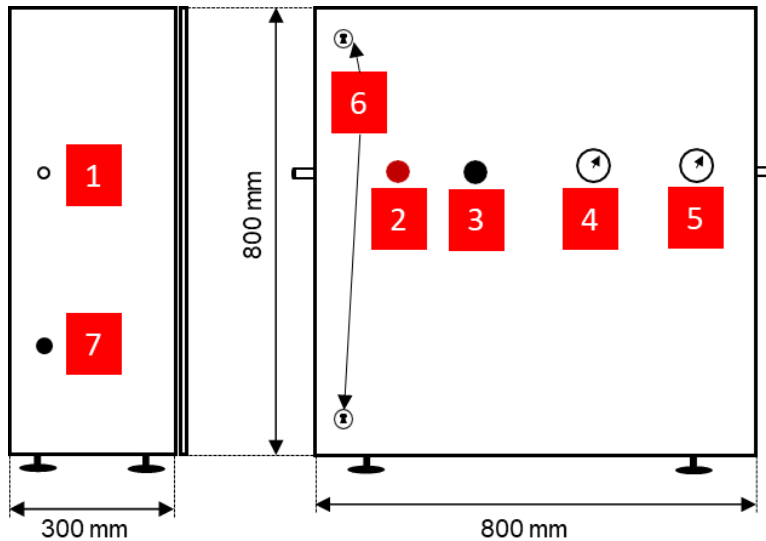

Figure 1: Cabinet Left Side and Front Exterior

### 1. Air inlet

Inlet pressure: 6-10 bar

Flow rate: ≤60 litres/minute

Fitting: ¼" BSP female (¼" NPT adaptors supplied)

Minimum inlet air quality: ISO 8573-1 Class 5.-.4

### 2. Emergency stop button (twist to release)

### 3. Power switch

### 4. Inlet pressure gauge

### 5. Outlet pressure gauge

### 6. Locks

The cabinet must be locked to maintain its IP rating.

### 7. Mains power input gland

Input power	Product Code
230 VAC	DFU02-230V-01-800-SS, DFU01-230V-1000-01-SS and DFU01-230-800-SS
110 VAC	DFU02-110V-01-800-SS and DFU01-110V-01-800-SS

Customer must wire power cable.

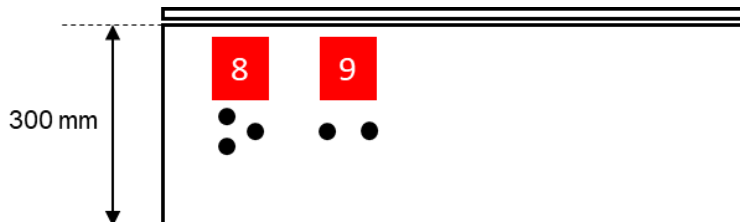

Figure 2: Cabinet Bottom Exterior

### 8. Oil and water drains

Do not obstruct the drains.

### 9. Exhaust silencers (also see Figure 5)

The unit will vent at timed intervals during normal operation. Do not obstruct the exhaust silencers.

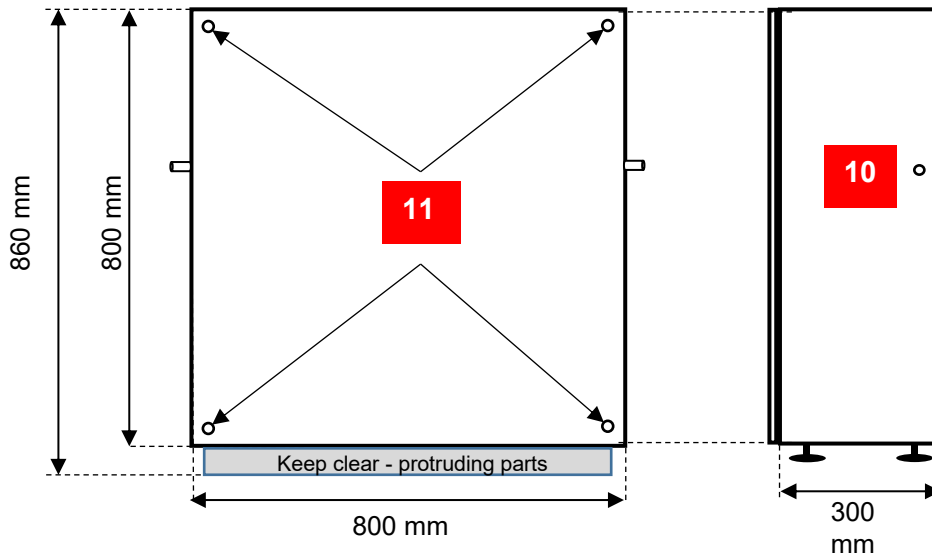

Figure 3: Cabinet Back Exterior and Right Side

**10. Air outlet**

¼" BSP female fitting. (¼" NPT adaptors supplied)

**11. Rear through holes for wall mounting**

Ø 9 mm. Keit recommends wall-mounting the unit, but it may also be free-standing on the provided feet.

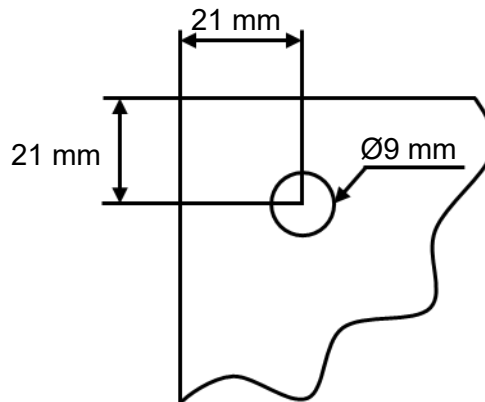

Figure 4: Rear through hole locations

### 1.3. DFU02 Components – Internal

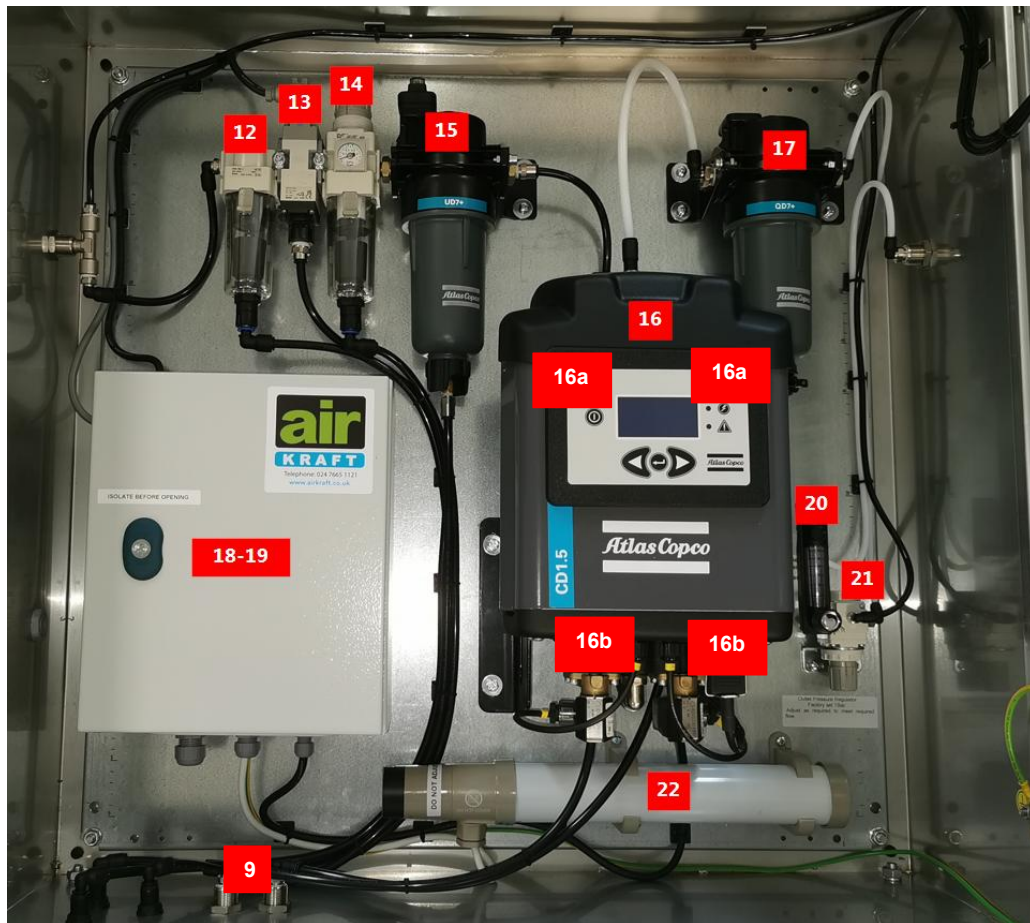

Figure 5: Internal view

- 12. SMC AFD30 Mist separator**
- 13. Shut-off valve**
- 14. SMC AW30 Filter (5µm) with inlet pressure regulator**  
The regulator is factory set to 10 bar. Do not adjust.
- 15. UD7+ Coalescing filter**  
rough filtering of oil aerosol & wet dust
- 16. CD1.5+ Desiccant Dryer**  
removal of moisture
- 16a. Desiccant cartridges**
- 16b. Solenoid valves**
- 17. QD7+ Activated carbon filter**  
removal of oil vapour
- 18. 24 V power supply**  
supplies item 13
- 19. 110 V-230 V transformer**  
(model-dependent)
- 20. Outlet flow regulator**  
0-30 litres/min; factory set to 2 L/min
- 21. Outlet pressure regulator**  
Factory set to 1 bar-g.
- 22. Frost protection**  
Factory-set thermostat. Do not adjust.

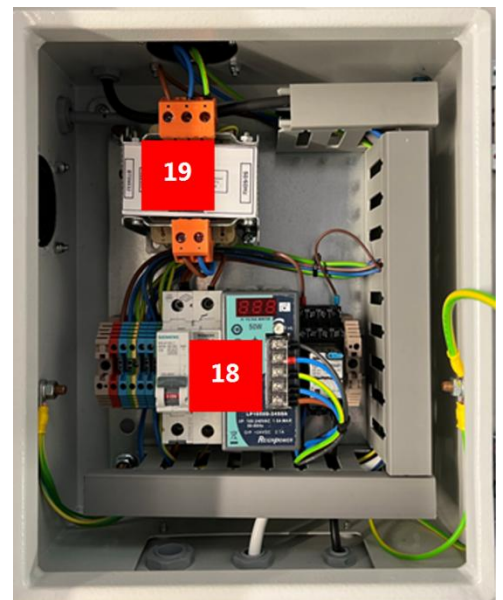

Figure 6: Electrical enclosure

## 2. USING THE DRYER

### 2.1. Starting the unit

1. Check that the Emergency shut off button (2) has not been engaged by twisting the button and feeling for a release.
2. Close the outlet flow control valve (10).
3. Connect the unit to a single-phase power supply (7) and to your compressed air supply (1).
4. Ensure that air is not escaping through the drain valve (8). If the inlet pipe is undersized, the initial pressure is too low, or pressure increases too slowly, the spring valve in the mist separator may fail to close—causing air to vent through the drain valve. If this occurs, briefly block the drain valve vents for a few seconds to allow the input pressure to rise, then rapidly release the vent to help the spring valve close properly.
5. Turn the unit on using the front panel switch (3). If the unit does not respond, check that the emergency stop button has not been depressed; twist to release.
6. Ensure that the inlet pressure gauge (4) reads the between 6 and 10 bar. The recommended pressure is 7 bar.
7. Leave the unit running for a minimum of three hours. This will ensure that the desiccant has regenerated, and the air outlet is dry.
8. Open the outlet flow control valve (10). Do not connect your spectrometer to the outlet valve at this point.
9. Set the outlet flow rate such that each spectrometer connected to the unit will receive 2 +/- 0.5 L/min, do this by opening the flow regulator (20). Take note of the flow rate set. For example, 5 spectrometers require a flow of 10 L/min.
10. Leave the unit running for a minimum of one hour. This will ensure that any dust or other contaminants in the air lines are cleared out and do not enter the IRmadillo.
11. For a single unit installation, connect the spectrometer to the dryer outlet (10) using Ø4 mm stainless steel or PTFE tube.  
For a multi-unit installation, connect your air drier to a manifold with an appropriate number of outlets. Connect to each spectrometer individually with Ø4 mm stainless steel or PTFE tube via a flow controller and balance the flow rate to each system so they each receive the recommended 2 L/min. See Appendix 4 for a system diagram.
12. Confirm that the measured flow rate is as set in step 8. If not, adjust the outlet flow control valve (20).
13. Close and lock the panel doors (6).

## 2.2. During regular use

The reservoirs on the mist separator (12) and 5µm filter (14) will gradually fill up as water is condensed out of the air. When full they will automatically empty themselves out of the drain vents (8) on the base of the unit.

A periodic observation check is advised to confirm they are draining effectively.

The bulbs can be manually emptied by turning the unit off using the front panel switch (3) and disconnect or isolate the air supply. This will open the spring valves on the mist separator and filter and allow the water to drain through the drain vents (8).

## 2.3. Stopping the unit

1. Turn off the unit using the front panel switch (3).
2. The compressed air in the unit will vent via the exhaust silencers on the base of the unit (9).

## 2.4. Long-term storage

The unit may be stored for up to six months at a temperature of 1-30°C in a non-condensing atmosphere. Keit recommends storing the unit in an indoor location. Maintenance should be carried out as per the schedule (see section 3.1).

### 3. MAINTENANCE

Maintenance must be performed periodically and only carried out by a suitably qualified and experienced person. Always turn off the unit by following the instructions in section 2.3 and isolate from power and compressed air supplies before conducting any maintenance. Ensure that the inlet line is not pressurised.

While undertaking maintenance on the compressed air dryer and filtration unit, the accompanying spectrometer measurements may drift due to increased humidity levels. Please see the section on “Purging the IRmadillo” in the relevant spectrometer user manual for more information on purging and stabilisation period.

For maintenance parts, please contact your Keit technical support team or email us at [support@keit.co.uk](mailto:support@keit.co.uk). Alternatively, you can reach out to your local Atlas Copco distributor for replacement kits.

For long term stability of IRmadillo measurements preventative maintenance must be performed. See section 3.1 for the schedule.

For instructions on how to replace individual components, please refer to section 4, Dryer Maintenance.

**IMPORTANT: If you have a DFU01 dryer, see appendix 5 & 6 of this document for maintenance information. Refer to image in section 1 to determine dryer model.**

### 3.1. Maintenance schedule

Frequency	Applicable dryers, Item, & Part No.	Activity
<b>Monthly</b>	<b>Visual Inspections</b>	
	Whole Unit	<ul style="list-style-type: none"> <li>• Pressure gauges read correct values</li> <li>• Flow regulator set correctly</li> <li>• No internal air or liquid leaks</li> <li>• Internal cables in good condition</li> </ul>
<b>Every year</b>	<b>Service A</b>	
	SMC AFD30 line filters PN: AFD30P-060AS	Replace filter elements found in: <b>Figure 5: Item 12, Follow section 4.1</b>
	SMC AW30 line filters PN: AF30P-060S	Replace filter elements found in: <b>Figure 5: Item 14, Follow section 4.2</b>
	Atlas Copco QD7+ line filter PN: 2901 2080 30	Replace filter elements found in: <b>Figure 5: Item 17, Follow section 4.2</b>
	Exhaust silencers PN: 04 01 7010	Replace silencers found in: <b>Figure 5: Item 9, Follow section 4.5</b>
	Atlas Copco UD7+ line filter PN: 2901 2079 50	Replace filter elements found in: <b>Figure 5: Item 15, Follow section 4.3</b>
<b>Every 2 years</b>	<b>Service B</b>	
	Includes Service A	Follow maintenance steps in Service A
	Atlas Copco CD1.5+ Dryer PN: 1629 2302 53	Replace desiccant cartridges found in: <b>Figure 5: Item 16a, Follow section 4.6</b>

Every 4 years	Service C	
	Includes Service A & B	Follow maintenance steps in Service A & B
	Atlas Copco CD1.5+ Dryer Atlas Copco PN: 1629 2302 56 Manufacturer PN: Buschjost 8240200.9101.02400	Replace exhaust solenoid valves found in: <b>Figure 5: Item 16b, Follow section 4.7</b>

### 3.2. Maintenance alarms

The Atlas Copco CD1.5+ dryer has a maintenance alarm that will display an alert when service is due. When you have carried out the maintenance, you will need to turn off the alarm as follows:

1. Open to the Alarm menu.
2. Select Service Alarm.
3. Press and hold the Enter button for at least 5 seconds.

## 4. DRYER MAINTENANCE

### 4.1. SMC AFD30 Filter Replacement

Task requires SMC AFD30 Filter Element (black); Part number AFD30P-060AS

**WARNING: UNIT MUST BE POWERED OFF AND DEPRESSURISED BEFORE PERFORMING THIS MAINTENANCE PROCEDURE.**



Figure 7: SMC AW30 Element



Figure 8: SMC AW30 disassembly



Figure 9: Bowl removed showing old filter



Figure 10: Old filter removed to reveal threaded core fastener

1. Identify SMC AFD30 filter element Figure 7.
2. Remove push fit drain hose Figure 8.
3. Push down the locking tab shown in Figure 8 and twist and pull the clear plastic filter bowl away from the filter head socket until the bowl disconnects from the assembly and set aside in a clean place.
4. The filter should now be visible, Figure 9.
5. Remove old the black filter, by twisting the filter down a standard right handed thread. Figure 10, the old sealing o-ring on the filter must be removed with the old filter.

## SMC AFD30 Filter Replacement Continued



Figure 11: New filter



Figure 12: Maintenance complete, unit reassembled

6. Insert the black replacement filter with new o-ring seal onto the filter head socket threaded shaft and tighten until resistance is felt and the filter is fully inserted. Figure 11.
7. Insert the filter bowl. The filter bowl's grey tab should insert in an off-centre position.
8. Push filter bowl into filter head socket with barbs and slots engaged until hard stop.
9. Twist the filter bowl until the grey tab is in a centred position and clicks into the filter head groove. Figure 12.
10. Fully reinsert the drainage hose back into the push fitting in the base of the filter bowl. Figure 12.
11. SMC AFD30 maintenance complete.

## 4.2. SMC AW30 Filter Replacement



Figure 13: SMC AW30 Element

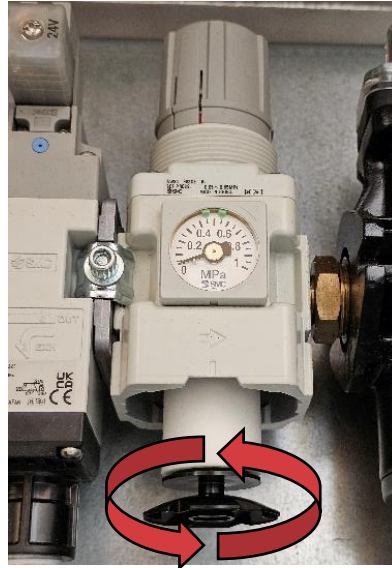

Figure 14: Bowl removed showing old filter

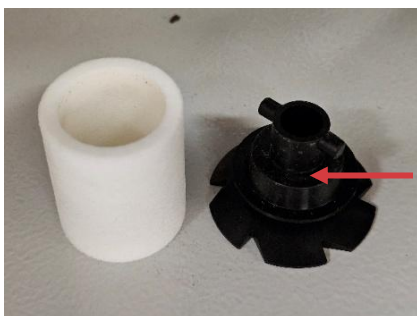

Figure 15: New filter and bayonet fastener

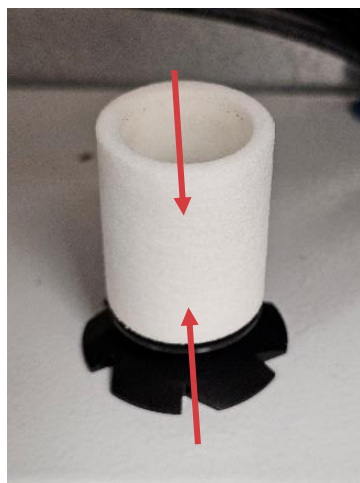

Figure 16: New filter preassembly ready for insertion

Task requires SMC AW30 Filter Element (white); Part number AF30P-060S

**WARNING: UNIT MUST BE POWERED OFF AND DEPRESSURISED BEFORE PERFORMING THIS MAINTENANCE PROCEDURE.**

1. Identify SMC AW30 filter element Figure 13.
2. Remove push fit drain hose Figure 13.
3. Pull down the grey locking tab shown in Figure 13 and twist and pull the clear plastic filter bowl away from the filter head socket until the bowl disconnects from the assembly and set aside in a clean place. Figure 14.
4. Remove the old white filter, by twisting the black plastic bayonet cap anticlockwise. Figure 14.
5. Discard old white filter.
6. Keep black bayonet fastener in a safe place. Figure 15.
7. With the black plastic bayonet fastener mounted inside the white filter as shown in figure 16.

## SMC AW30 Filter Replacement Continued



Figure 17: Female bayonet reciprocal on SMC AW30



Figure 18: Maintenance complete, unit reassembled

8. Insert the loose assembly into the filter head socket. Figure 17.
9. Fasten the filter by twisting the black plastic bayonet cap on to the filter clockwise until the barbs locate into the female connector channels. Figure 17.
10. Tighten until the filter is locked into position.
11. Insert the filter bowl. Align the filter bowl's grey tab as shown in Figure 18.
12. Push filter bowl into filter head socket with barbs and slots engaged until hard stop.
13. Twist the filter bowl until the grey tab clicks into the filter head groove.
14. Reinsert the drainage hose back into the push fitting in the base of the filter bowl. Figure 18.
15. SMC AW30 maintenance complete.

### 4.3. UD7+ Filter Replacement



Figure 19: UD7+ Filter Element



Figure 20: Push fit drain removed



Figure 21: Filter bowl removed showing old UD7+ filter



Figure 22: Filter with excessive O-ring lubricant grease

Task requires UD7+ Filter Element Kit; Part number 2901 2079 50

**WARNING: UNIT MUST BE POWERED OFF AND DEPRESSURISED BEFORE PERFORMING THIS MAINTENANCE PROCEDURE.**

1. Identify UD7+ Filter element Figure 19.
2. Remove push fit drain hose Figure 20.
3. Unscrew filter bowl and set aside in a clean place. Figure 21.
4. Remove old UD7+ filter, make note of its orientation in the filter head socket. Figure 21.
5. Discard of the old filter.

**WARNING: if o-ring grease is on any parts, wipe it clean. Do not use solvent. The presents of grease in the air dryer filtration system could irreparably damage the IRmadillo. Figure 22.**

## UD7+ Filter Replacement Continued



Figure 23: New UD7+ filter



Figure 24: Inserting new UD7+ filter



Figure 25: New UD7+ filter inserted



Figure 26: Filter bowl fastened with no gap at seam

6. Insert the replacement filter into the filter head socket. The filter should click into place in the same orientation as the old filter. Figure 24.
7. Replace o-ring on filter bowl, with new part found in filter kit. Figure 25.
8. Screw filter bowl back into filter head until their flanges meet a hard stop.
9. Reinsert the drainage hose back into the push fitting in the base of the filter bowl. Figure 26.
10. UD7+ maintenance complete.

## 4.4. QD7+ Filter Replacement



Figure 27: QD7+ Filter Element



Figure 28: Filter bowl removed showing old QD7+ filter



Figure 29: Filter with excessive O-ring lubricant grease



Figure 30: New QD7+ filter

Task requires QD7+ Filter Element Kit; Part number 2901 2080 30

**WARNING: UNIT MUST BE POWERED OFF AND DEPRESSURISED BEFORE PERFORMING THIS MAINTENANCE PROCEDURE.**

1. Identify QD7+ Filter element Figure 27.
2. Unscrew filter bowl and set aside in a clean place. Figure 28.
3. Remove old QD7+ filter, make note of its orientation in the filter head socket. Figure 28.
4. Discard of the old filter.

**WARNING: if o-ring grease is on any parts, wipe it clean. Do not use solvent. The presents of grease in the air dryer filtration system could irreparably damage the IRmadillo. Figure 29.**

## QD7+ Filter Replacement Continued



Figure 31: New QD7+ filter inserted



Figure 32: Filter bowl fastened with no gap at seam

5. Insert the replacement filter into the filter head socket. The filter should click into place in the same orientation as the old filter. Figure 31.
6. Replace o-ring on filter bowl, with new part found in filter kit. Figure 31.
7. Screw filter bowl back into filter head until their flanges meet a hard stop. Figure 32.
8. QD7+ maintenance complete.

## 4.5. Exhaust Silencers Replacement



Figure 33: Exhaust silencers location



Figure 34: Identifying which fitting to remove



Figure 35: Exhaust silencer



Figure 36: Fastened silencers

Task requires 2x Exhaust Silencers; Part number 04 01 7010

**WARNING: UNIT MUST BE POWERED OFF AND DEPRESSURISED BEFORE PERFORMING THIS MAINTENANCE PROCEDURE.**

1. Identify Exhaust Silencers Figure 33.
2. The silencer is the smaller of the two hexagonals. Figure 34.
3. Remove both old silencers by unscrewing the body with a spanner Figure 34.
4. Fit new Exhaust silencers. Figure 35.
5. Tighten the threaded silencer until hard stop. Figure 36.
6. Perform this for procedure again for the opposite silencer.
7. Exhaust silencers maintenance complete.

## 4.6. CD1.5+ Desiccant Cartridge Replacement



**Figure 37: CD1.5 desiccant dryer**



**Figure 38: Removing push fit piping**



**Figure 39: Cover fasteners locations**



**Figure 40: Cover removed exposing desiccant chamber cap**

Task requires CD1.5 Desiccant Cartridge Kit; Part number 1629 2302 53

**WARNING: UNIT MUST BE POWERED OFF AND DEPRESSURISED BEFORE PERFORMING THIS MAINTENANCE PROCEDURE.**

1. Identify CD1.5 Desiccant Dryer Figure 37.
2. Remove push fit drain hose from the top of the dryer Figure 38.
3. Remove the 4x Screws (2x screws on either side) shown in figure 39.
4. Lift off black dryer top cover Figure 40.

## CD1.5+ Desiccant Cartridge Replacement Continued



Figure 41: Removing cap fasteners



Figure 42: Removed cap reveals desiccant cartridges



Figure 43: New desiccant cartridge



Figure 44: Desiccant chamber cartridge key ways



Figure 45: Cartridge reciprocal keys



Figure 46: Desiccant chamber cap with new gasket

5. Remove the 10x Screws. Making note of which screws came from which holes. Figure 41.
6. Remove black desiccant cap shown in figure 41.
7. Pull out old cartridges by the black handles shown in figure 42.
8. Discard old desiccant cartridges.
9. Insert new cartridges into the desiccant chambers. Figure 43.
10. The cartridges can only be inserted in the correct orientation due to the keyed tips. Rotate until the cartridge vertically drops into place. Figure 44 & 45.

## CD1.5+ Desiccant Cartridge Replacement Continued



**Figure 47: (LEFT) Good cartridge installation cartridge – (RIGHT) Bad cartridge installation**



**Figure 48: Cap fastened with screws**



**Figure 49: Maintenance completed**

11. Push cartridges in firmly. You should feel resistance from their o-ring seals. The Cartridge should click into place and sit fully inserted into the chamber. see figure 47.

12. Replace end cap with new gasket from kit. Figure 46.

13. Assembly end cap back over the desiccant chambers, check that the gasket placement on the end cap is well positioned for a good seal. See figure 48.

14. Return all 10x screws to their end cap hole locations as noted earlier and tighten screw to 8 N.m.

15. Reattach black dryer top cover with 4x screws.

16. Insert purge pipe back into push fit fitting on the top of the dryer. Figure 49.

17. CD1.5 Desiccant maintenance complete.

## 4.7. CD1.5+ Solenoid Valve Replacement



**Figure 50: Solenoid valves location**

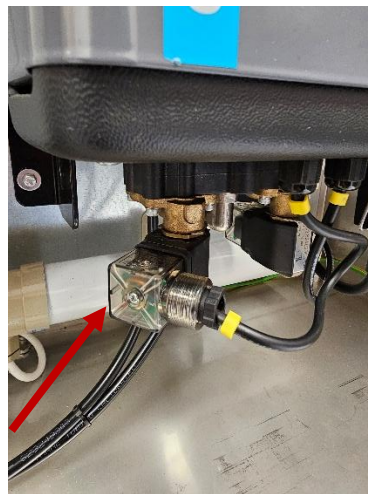

**Figure 51: Solenoid valve plug fastener removal**

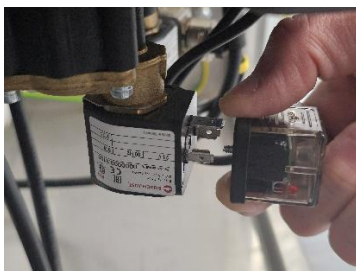

**Figure 52: Correctly disconnecting solenoid valve plug**



**Figure 53: Removing solenoid body fasteners**

Task requires CD1.5 Solenoid Valve Kit;  
Part number 1629 2302 56

**WARNING: UNIT MUST BE POWERED OFF AND DEPRESSURISED BEFORE PERFORMING THIS MAINTENANCE PROCEDURE.**

1. Identify CD1.5 dryer solenoid valves Figure 50.
2. Rotate the solenoids black body until the clear plastic plugs faces toward you with the fastening screw showing. Figure 51.
3. Loosen the screw fastening the clear plastic plug to the solenoid body until plug can be removed. Figure 52.
4. Disconnect the solenoid valve plug.

**BEWARE:** The clear plastic cover is now loose.

**TO REMOVE CORRECTLY:** Pinch the top and bottom of the clear plastic cover and the rubber gasket at the same time. The plug internal must disconnect with the cover. See figure 52.

**STOP IF:** the plug is seized onto the solenoid pins and the internals are coming out when pulling the plug cover. Incorrect removal will damage the wiring.

An insulated tool may be used to aid the removal of the plug internals.

5. Making note of which screws came from which holes. Remove the 4x screws holding the solenoids brass plate to the base of the dryer. Figure 53.

## CD1.5+ Solenoid Valve Replacement Continued



**Figure 54: Solenoid valve with diaphragm correctly orientated**



**Figure 55: Solenoid diaphragm key hole alignment**



**Figure 56: Diaphragm key alignment with housing key way**



**Figure 57: Solenoid seated without gap or diaphragm pinching**



**Figure 58: Pin insert alignment for plug and fastener**

6. Discard the old solenoid.
7. Fit the new solenoid valve assembly with the rubber diaphragm points facing up as see in Figure 54.
8. The rubber diaphragm has a key on one side with a hole in it. The keys hole must be aligned with the hole in the solenoid brass base. Figure 55.
9. Lift the replacement solenoid into its assembly position with the diaphragm facing up. The key on the diaphragm must locate into the keyed profile seen in Figure 56.
10. The solenoid brass base must seat with no gaps present. The diaphragm must not be pinched. Figure 57.
11. Tighten all 4x screws back into their holes. All screw must have their locking washers on. Figure 57.
12. Reconnect the solenoid plug on to the 3 pin solenoid terminal. See Figure 58.
13. Tighten the fastening screw at the core of the plug until the rubber gasket is compressed. Do not over tighten.
14. Repeat this procedure on the opposite solenoid.
15. CD1.5 Solenoid maintenance complete.

## 5. TECHNICAL SPECIFICATIONS

Power Supply	Value
Voltage (Standard)	240 VAC
Voltage (Option)	110 VAC
Recommended Supply Type	Single phase, 13 A
Approximate Maximum Load	100 W
Recommended Fuse	5 A

Limits	Units	Min	Recommended	Max
Compressed air inlet pressure	Bar(g)	6	7	10
Ambient temperature	°C	-10	-	55
Inlet compressed air temperature	°C	1.5	35	60
Inlet compressed air humidity	%RH	0	-	100
Inlet compressed air flow	litres/min	-	-	60

Compressed Air Quality to ISO 8573-1	Particulate	Water	Oil
Inlet compressed air quality - minimum class requirement	5	-	4
Outlet compressed air quality class	1	2	1

Other	Value
Dimensions	H800 x W800 x D300 mm
Panel IP rating (doors shut and locked)	IP54 (Nema 3)
Siting requirements	Avoid direct sunlight

## 6. LIST OF PARTS

Refer to the parts list checklist attached to the inside of the door to confirm the following (expected) part numbers:

<b>DFU01 Parts List</b>	<b>Part No.</b>	<b>Manufacturer</b>
Atlas Copco Dryer CD1.5+	8102361763	Atlas Copco
Atlas Copco UD+ series, Coalescing filter (G1/2")	See part	Atlas Copco
Atlas Copco CD1.5+ Mount Bracket	CDBR261802	Atlas Copco
Atlas Copco QD+ series, Activated carbon filter (1/2")	See part	Atlas Copco
SMC Mist Separator G1/4"	SMAFD30	SMC
SMC 3/2 Valve G3/8" 24Vdc Modular	SMVP517Y	SMC
Flow Controller (1 l/min)	2510A4A40BVBN	Key Instruments
Filter/Reg G1/4 (Auto drain) square gauge	SMAW30	SMC
Regulator G1/4"	SMAR20	SMC
Heater & Thermostat Control - 40W	1FT-TUHE-STAT	Dimplex
Electrical Enclosure H186 x W120 x D126 (230V Small)	EUMC18CD-230	Europa Components
Power Supply - 40v-24VDC 2.5A	OMPS230-24 /	Reign power
	LP1050D-24SDA	
Relay - 24CDC	RERN2-2012	Relpol S.A.
Breaker -Europa B2 230V	EUBRB2-230	Europa Components
Breaker -Europa C6 230V	EUBRC6-230	Europa Components
Large Internal Enclosure (110/230V Transformer)	EUMC65C-110	Europa Components
Transformer 110V/230V 100W (100VA)*	110-230-BT58711	Birmingham Transformers Ltd

\*Transformer is fitted to 110 V models only.

## 7. WARRANTY

The manufacturer's warranty lasts 12 months from the date of shipment.

Warranty is on a return-to-manufacturer basis although the major components are covered globally by the respective manufacturers via local distributor networks.

Find your nearest distributor or service centre via the manufacturer's websites:

Atlas Copco: <https://www.atlascopco.com/en-uk/sys/in-your-country>

SMC Pneumatics: <https://www.smc.eu/en-gb/worldwide-addresses>

## 8. APPENDIX 1 – ELECTRONICS ENCLOSURE DETAIL VIEW

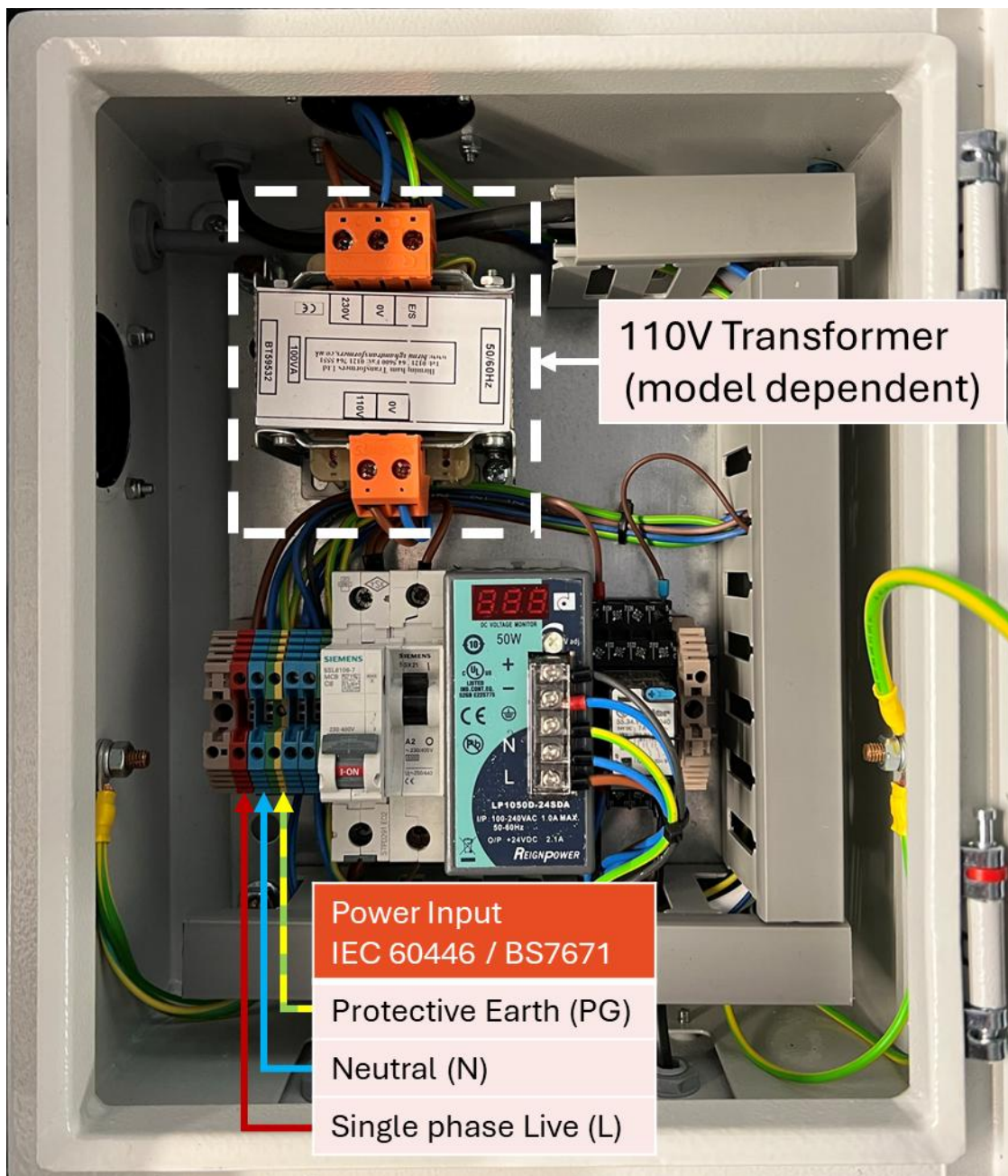
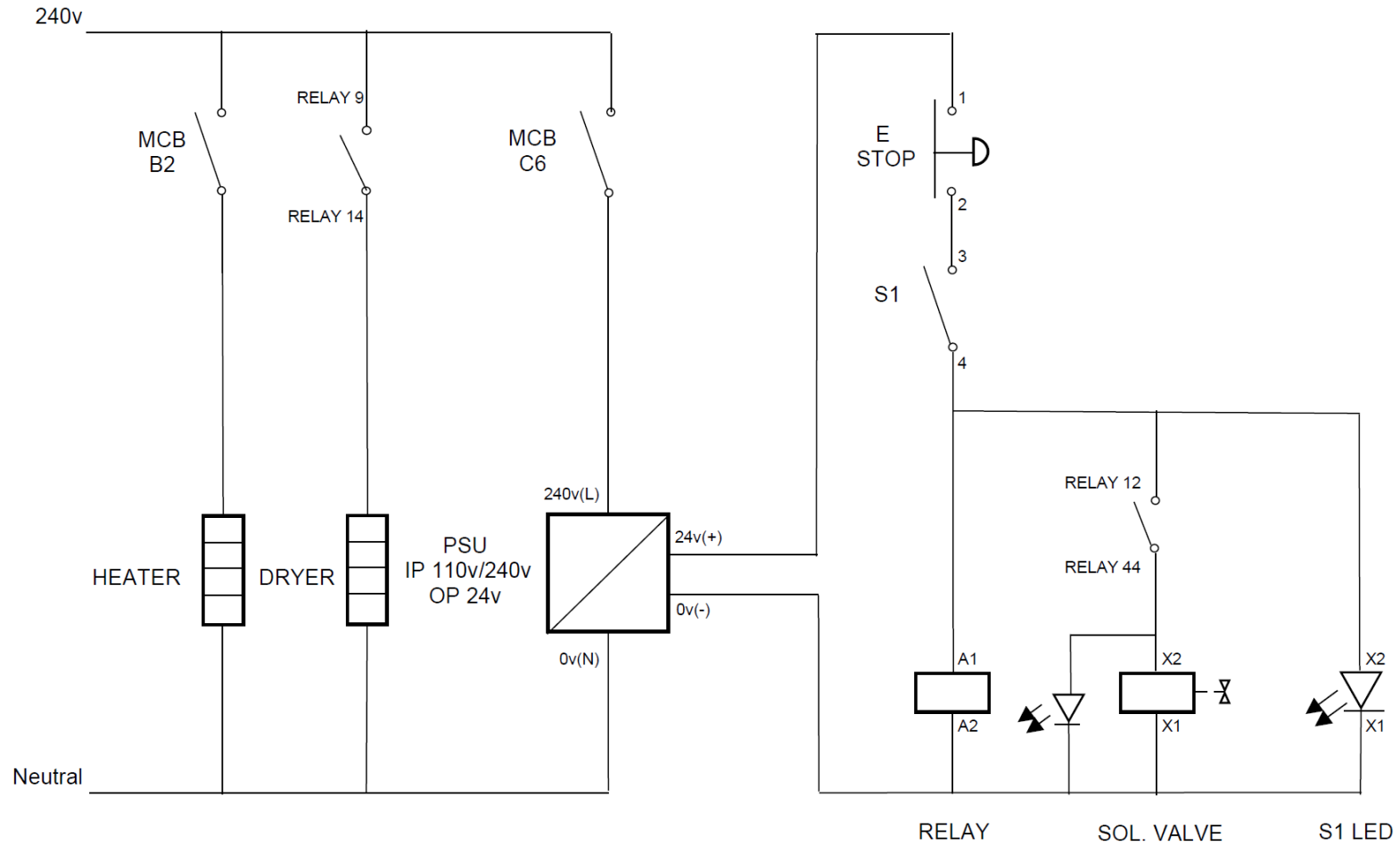
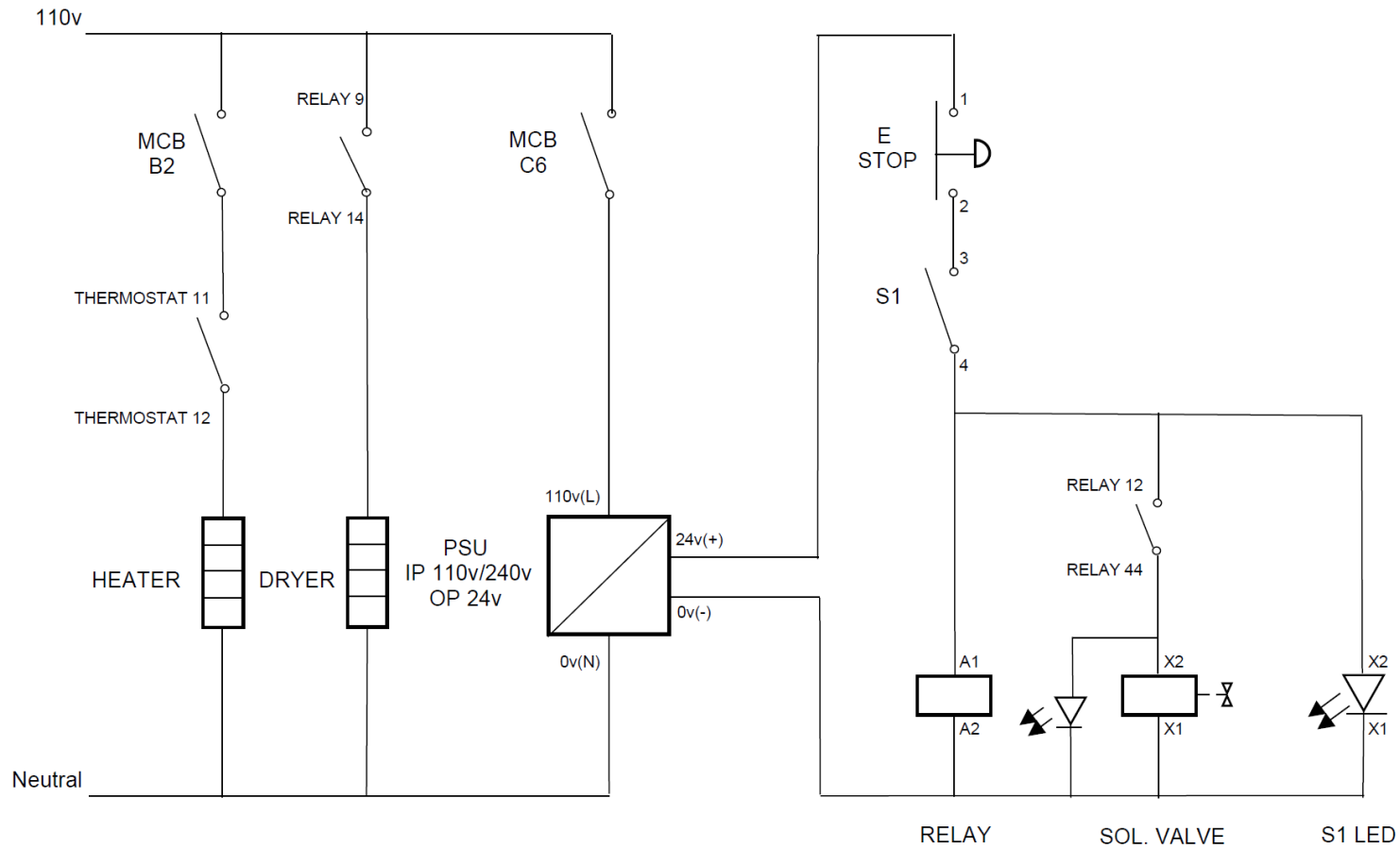

Figure 59: Single phase power should be connected via the labelled connectors for both 110V and 240V models.

## 9. APPENDIX 2 – CIRCUIT DIAGRAM FOR 240V VERSION



## 10. APPENDIX 3 – CIRCUIT DIAGRAM FOR 110V VERSION



## 11. APPENDIX 4 – PURGE SETUP FOR MULTIPLE INSTRUMENTS

Example using a manifold with X instruments.

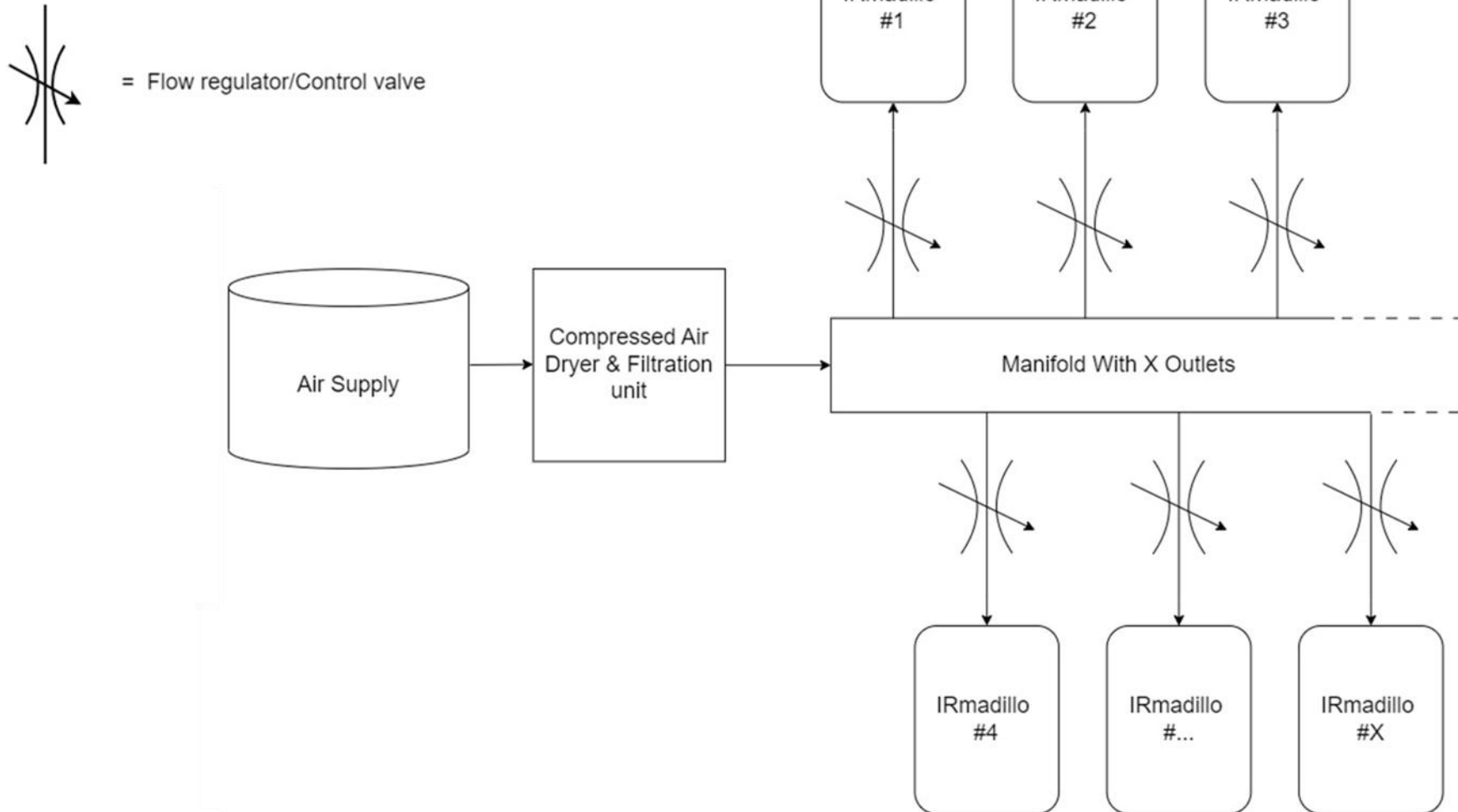

# MAINTENANCE SCHEDULE TABLE PRINT OUT



## ATTACH TO DRYER UNIT

SERVICE	DATE OF INSTALL:.....	DATE MAINTAINED			
	Item	Year 1	Year 2	Year 3	Year 4
S-A	SMC AFD30 Filter Element (black) Part Number: AFD30P-060AS				
	SMC AW30 Filter Element (white) Part Number: AF30P-060S				
	UD7+ Filter Element Kit Part Number: 2901 2079 50				
	QD7+ Filter Element Kit Part Number: 2901 2080 30				
	Exhaust Silencers Part Number: 04 01 7010				
S-B	Cartridge Kit Desiccant Part Number: 1629 2302 53				
S-C	Solenoid Valve Kit Part Number: 1629 2302 56				

## 12. APPENDIX 5 – DFU01 DRYER INTERNAL COMPONENTS



Figure 59: Internal view

- 12. SMC AFD30 Mist separator**
- 13. Shut-off valve**
- 14. SMC AW30 Filter (5µm) with inlet pressure regulator**  
The regulator is factory set to 10 bar. Do not adjust.
- 17. QD7+ Activated carbon filter**  
removal of oil vapour
- 18. 24 V power supply**  
supplies item 13
- 19. 110 V-230 V transformer**  
(model-dependent)
- 20. Outlet flow regulator**  
0-30 litres/min; factory set to 2 L/min
- 21. Outlet pressure regulator**  
Factory set to 1 bar-g.
- 22. Frost protection**  
Factory-set thermostat. Do not adjust
- 23. DD7+ Coalescing Filter**  
Rough filtering of oil aerosol & wet dust
- 24. PD3 Coalescing filter**  
Fine filtering of oil aerosol & wet dust
- 25. Desiccant Dryer CD1+**  
removal of moisture

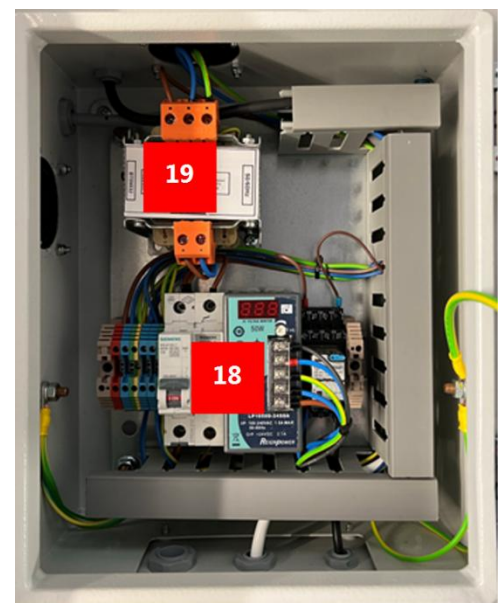

Figure 60 : Electrical enclosure

### 13. APPENDIX 6 – DFU01 DRYER MAINTENANCE SCHEDULE

Currently the recommendation is to have these dryer components serviced by their respective manufacturer. In the table below you can find the work that is needed to be conducted and associated parts numbers.

If you have any questions or concerns please contact us at [support@keit.co.uk](mailto:support@keit.co.uk).

Frequency	Applicable dryers, Item, & Part No.	Activity
<b>Monthly</b>	<b>Visual Inspections</b>	
	Whole Unit	<ul style="list-style-type: none"> <li>• Pressure gauges read correct values</li> <li>• Flow regulator set correctly</li> <li>• No internal air or liquid leaks</li> <li>• Internal cables in good condition</li> </ul>
<b>Every year</b>	<b>Service A</b>	
	SMC AFD30 line filters PN: AFD30P-060AS	Replace filter elements: <b>Arrange maintenance from a local SMC Pneumatics representative</b>
	SMC AW30 line filters PN: AF30P-060S	Replace filter elements: <b>Arrange maintenance from a local SMC Pneumatics representative</b>
	Atlas Copco QD7+ line filter PN: 2901 2080 30	Replace filter elements: <b>Arrange maintenance from a local Atlas Copco representative</b>
	Exhaust silencers PN: 04 01 7010	Replace silencers: <b>Arrange maintenance from a local Atlas Copco representative</b>
	Atlas Copco DD7+ line filter PN: 2901 2079 10	Replace filter elements: <b>Arrange maintenance from a local Atlas Copco representative</b>
	Atlas Copco PD3 line filter PN: 2902 0212 00	Replace filter elements: <b>Arrange maintenance from a local Atlas Copco representative</b>

Every 2 years	Service B	
	Includes Service A	Follow maintenance steps in Service A: <b>Arrange maintenance from a local Atlas Copco representative</b>
	Atlas Copco CD1+ Dryer PN: 2230 0040 00	Replace desiccant cartridges: <b>Arrange maintenance from a local Atlas Copco representative</b>

Every 4 years	Service C	
	Includes Service A & B	Follow maintenance steps in Service A&B: <b>Arrange maintenance from a local Atlas Copco representative</b>
	Atlas Copco CD1+ Dryer PN: 2230 0040 15	Replace exhaust solenoid valves: <b>Arrange maintenance from a local Atlas Copco representative</b>
	Atlas Copco CD1+ Dryer PN: 2230 0040 11	Replace Control valve: <b>Arrange maintenance from a local Atlas Copco representative</b>

### Resources

**Atlas Copco:** <https://www.atlascopco.com/en-uk/sys/in-your-country>

**SMC Pneumatics:** <https://www.smc.eu/en-gb/worldwide-addresses>